



■ Features :

- AC 180~260VAC input
- PF> 0.98@ 230VAC
- Protections: Short circuit/ Overload/ Over voltage/ Over temperature
- Built in remote sense function
- Built-in remote ON-OFF control
- Power good signal
- With parallel function(N+1)
- Can adjust from 20~100% output voltage by external control 1-5V
- Forced air cooling by built-in DC fan
- 3 years warranty



SPECIFICATION

| ORDER NO. | SCP-800-09 | SCP-800-12 | SCP-800-15 | SCP-800-18 | SCP-800-24 | SCP-800-36 | SCP-800-48 | SCP-800-60 | |
|-----------------------------------|--|--|------------|------------|--|------------|------------|------------|----------|
| SAFETY MODEL NO. | 800S-P009 | 800S-P012 | 800S-P015 | 800S-P018 | 800S-P024 | 800S-P036 | 800S-P048 | 800S-P060 | |
| DC VOLTAGE | 9V | 12V | 15V | 18V | 24V | 36V | 48V | 60V | |
| RATED CURRENT | 88A | 66A | 53A | 44.4A | 33A | 22.2A | 16A | 13A | |
| CURRENT RANGE | 0 ~ 88A | 0 ~ 66A | 0 ~ 53A | 0 ~ 44.4A | 0 ~ 33A | 0 ~ 22.2A | 0 ~ 16A | 0 ~ 13A | |
| RATED POWER | 792W | 792W | 795W | 800W | 792W | 800W | 768W | 780W | |
| OUTPUT | RIPPLE & NOISE (max.) Note.2 | 90mVp-p | 120mVp-p | 150mVp-p | 180mVp-p | 240mVp-p | 360mVp-p | 480mVp-p | 500mVp-p |
| | VOLTAGE ADJ. RANGE | ±3.0% Typical adjustment by potentiometer | | | 20% ~ 100% adjustment by 1 ~ 5VDC external control | | | | |
| | VOLTAGE TOLERANCE Note.3 | ±1.5% | ±1.0% | ±1.0% | ±1.0% | ±1.0% | ±1.0% | ±1.0% | ±1.0% |
| | LINE REGULATION | ±0.5% | ±0.5% | ±0.5% | ±0.5% | ±0.5% | ±0.5% | ±0.5% | ±0.5% |
| | LOAD REGULATION | ±1.0% | ±0.5% | ±0.5% | ±0.5% | ±0.5% | ±0.5% | ±0.5% | ±0.5% |
| | SETUP, RISE, HOLD TIME | 800ms, 400ms, 12ms at full load | | | | | | | |
| INPUT | VOLTAGE RANGE | 180 ~ 260VAC 260 ~ 370VDC see the derating curve | | | | | | | |
| | FREQUENCY RANGE | 47 ~ 63Hz | | | | | | | |
| | POWER FACTOR | >0.98 / 230VAC | | | | | | | |
| | EFFICIENCY (Typ.) | 83% | 84% | 85% | 86% | 88% | 88% | 89% | 90% |
| | AC CURRENT | 5.0A / 230VAC | | | | | | | |
| | INRUSH CURRENT (max.) | 60A / 230VAC | | | | | | | |
| | LEAKAGE CURRENT(max.) | 3.5mA / 240VAC | | | | | | | |
| PROTECTION | OVER LOAD Note.4 | 105~115% rated output power Protection type : Current limiting, delay shut down o/p voltage, re-power on to recover | | | | | | | |
| | OVER VOLTAGE | 110 ~ 135% Follow to output set up point Protection type : Shut down o/p voltage, re-power on to recover | | | | | | | |
| | OVER TEMPERATURE | >100°C / measure by heat sink, near transformer Protection type : Shut down o/p voltage, recovers automatically after temperature goes down | | | | | | | |
| ENVIRONMENT | WORKING TEMP. | -20 ~ +65°C (Refer to output load derating curve) | | | | | | | |
| | WORKING HUMIDITY | 20 ~ 90% RH non-condensing | | | | | | | |
| | STORAGE TEMP., HUMIDITY | -20 ~ +85°C 10~95% RH | | | | | | | |
| | TEMP. COEFFICIENT | ±0.04% / °C (0 ~ 50°C) | | | | | | | |
| | VIBRATION | 10 ~ 200Hz, 2G 10min./1cycle, 60min. each along X, Y, Z axes | | | | | | | |
| SAFETY & EMC (Note. 5) | SAFETY STANDARDS | UL60950, TUV EN60950-1 Approved | | | | | | | |
| | WITHSTAND VOLTAGE | I/P-O/P:3KVAC I/P-FG:1.5KVAC O/P-FG:0.5KVAC | | | | | | | |
| | ISOLATION RESISTANCE | I/P-O/P, I/P-FG, OP/FG:100M Ohms / 500VDC | | | | | | | |
| | EMI CONDUCTION & RADIATION | Compliance to EN55022 (CISPR22) class A | | | | | | | |
| | HARMONIC CURRENT | Compliance to EN61000-3-2,3 | | | | | | | |
| | EMS IMMUNITY | Compliance to EN61000-4-2,3,4,5,6,8,11, Light industry level, criteria A | | | | | | | |
| OTHERS | POWER GOOD SIGNAL | Open collector of NPN transistor | | | | | | | |
| | SPECIAL FUNCTION | DC Voltage Adj., remote sensing, remote control, parallel operation(refer to control terminal instruction manual) | | | | | | | |
| | COOLING | By fan, >20% load or >50°C fan on | | | | | | | |
| | MTBF | 74.9K hrs min. MIL-HDBK-217F(25°C) | | | | | | | |
| | DIMENSION | 290*120*68mm (L*W*H) | | | | | | | |
| | PACKING | 2.3kg; 8pcs / 20kg / CARTON | | | | | | | |
| NOTE | <p>1. All parameters NOT specially mentioned are measured at 230VAC input, rated load and 25°C of ambient temperature.</p> <p>2. Ripple & noise are measured at 20MHz of bandwidth by using a 12" twisted pair-wire terminated with a 0.1uf & 47uf parallel capacitor.</p> <p>3. Tolerance : includes set up tolerance, line regulation and load regulation.</p> <p>4. Current limiting 3 times(1.5s,3.0s,5.0s)Then intelligent auto recovery before shut down</p> <p>5. The power supply is considered a component which will be installed into a final equipment. The final equipment must be re-confirmed that it still meets EMC directives.</p> | | | | | | | | |

Mechanical Specification

Unit:mm

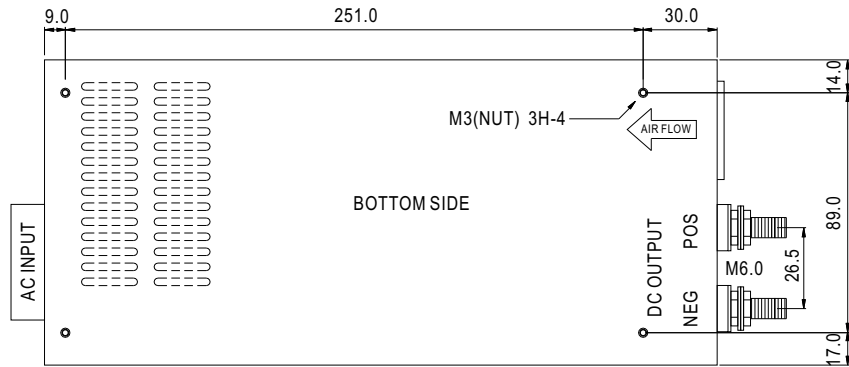
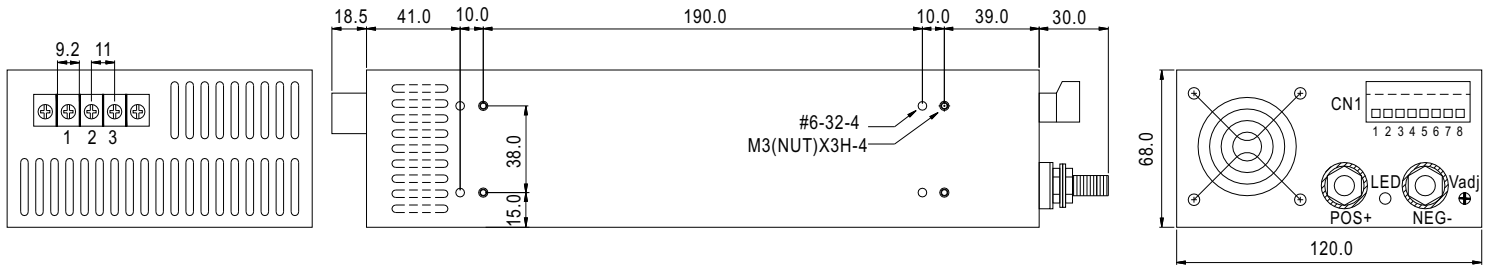

Terminal Pin. No. Assignment

| Pin No. | Assignment |
|---------|------------|
| 1 | AC/L |
| 2 | AC/N |
| 3 | FG \perp |

Control terminal Pin. No. Assignment (CN1) : Dinkle 51HDBC-O8P or equivalent

| Pin No. | Assignment | Pin No. | Assignment | Mating With |
|---------|------------|---------|------------|-----------------------------------|
| 1 | VS+ | 5 | PG | Dinkle 51SDB-O8P or equivalent |
| 2 | VS- | 6 | PAR | |
| 3 | VCI | 7 | GND | |
| 4 | VCO | 8 | INH | |

Derating Curve

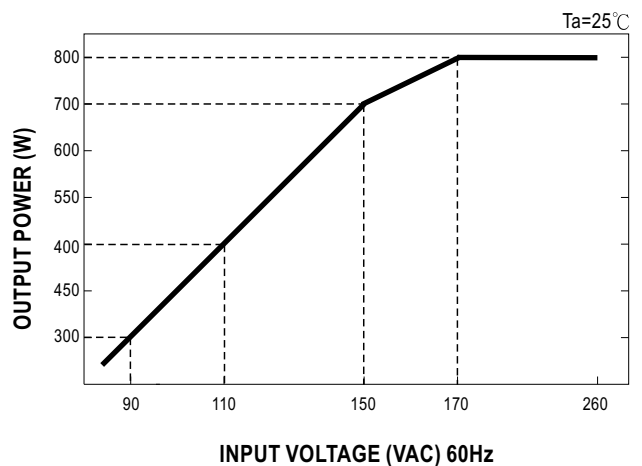
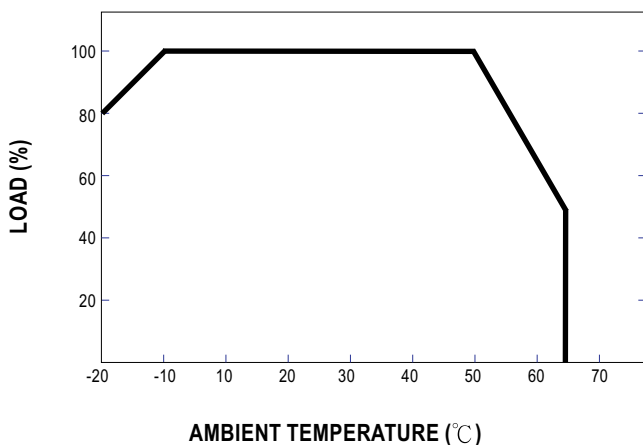

Control terminal instruction manual

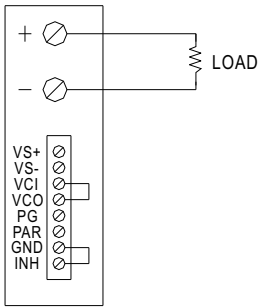

USING INTERNAL VOLTAGE CONTROL

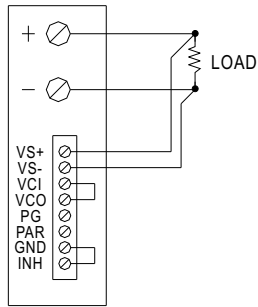

REMOTE SENSING

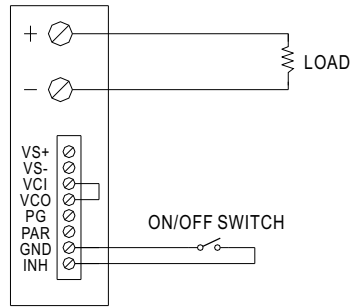

ON/OFF CONTROL BY SWITCH

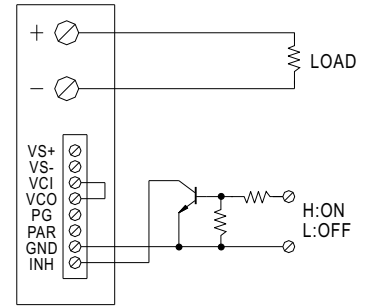

ON/OFF CONTROL BY TRANSISTOR

GOOD : LED OFF
FAIL : LED ON

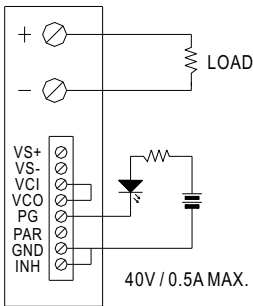

POWER GOOD SIGNAL

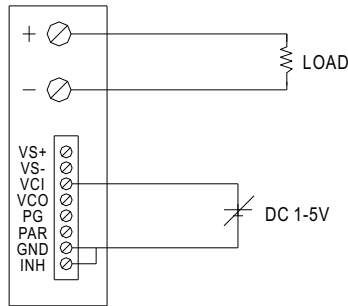

OUTPUT VOLTAGE ADJUST WITH DC 1-5V

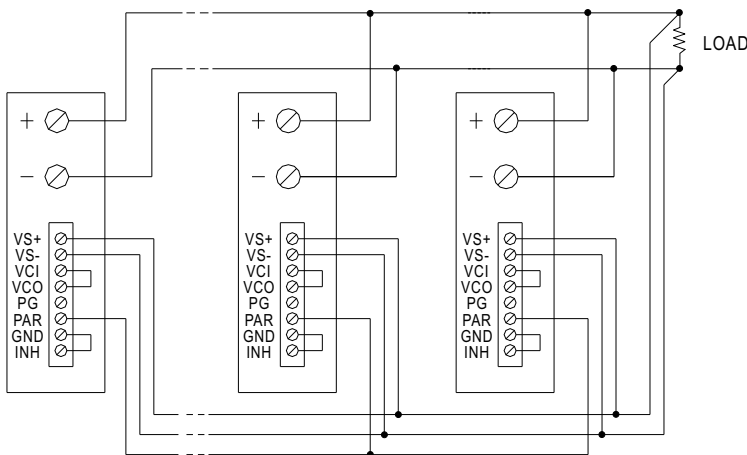
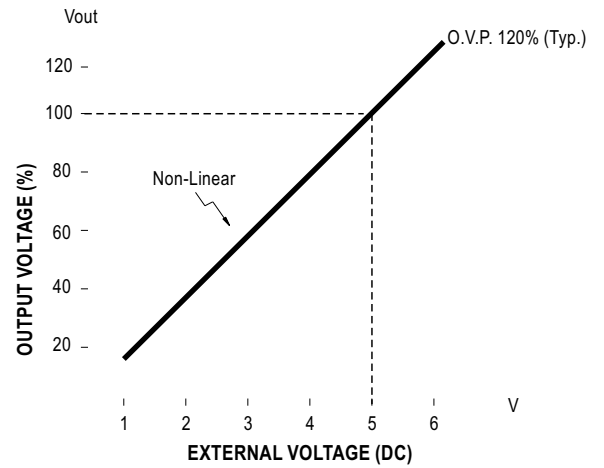

PARALLEL OPERATION WITH REMOTE SENSING

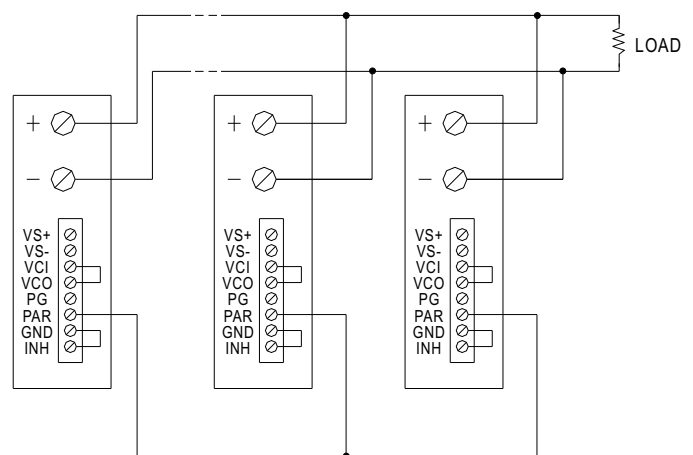

PARALLEL OPERATION WITHOUT REMOTE SENSING